

CONNECT AND CONTROL

Smart locks get smarter. The CL4500 range of locks offers the Codelocks smart lock features but in a smaller, sleeker lock model.

The CL4500 lock range combines smart technology with traditional keypad and card access options suitable for a wide range of applications, from building managers to home rental owners. Utilising Codelocks NetCode technology, the locks offer flexibility and convenience that enable businesses to recognise new levels of convenient access control without compromising on security.

CL4500
Smart
Lock



Easy Operation

Operate and manage locks directly via the keypad or via any Bluetooth compatible smartphone by downloading the K3 Connect App. Program locks via your smartphone, generate and send codes for easy access, issue smart cards for alternative entry, track and control via audit trail. The App is available on Apple App Store for Apple devices or Google Play™ for Android™ devices by searching for K3 Connect. The lock does not require Wi-Fi connection for operation. This significantly increases its potential for use in areas where Wi-Fi is unavailable or intermittent, adding to the benefits of this innovative product line.

Code Card Phone

The CL4500 range of locks provides flexibility and convenience by providing a range of access methods allowing you to choose the most suitable entry method for your application. Allow clients access via a simple code, allocate and register a MIFARE® compatible card or send an invitation to their phone.

NetCode

Generate and send time-sensitive codes to end users using the K3 Connect App or NetCode portal. Set codes for a specific start date and time and that automatically expire after a set duration. Additional features include blocking NetCodes and setting Flexi NetCodes.

Controlled Code Free

Set the lock into Code Free mode at fixed times of the day, reducing administration time and allowing users open access.

Audit Trail

Keep track on who, when and where the lock was accessed. Download and view the lock audit trail data.

CL4500
electronic

FUNCTIONS

CL4510

Mortice Latch

Outside lever turns freely without operating the latchbolt. When a valid code, card or smartphone is accepted, the keypad lights and the lever will retract the latchbolt. When the door closes the spring latch will automatically lock the door. Set the lock into Code Free access period so that anyone can open the door without using a code.

CODE CHANGE METHOD

On door via keypad or via a compatible smartphone by downloading the K3 Connect App.

AUXILIARY CONNECTIONS

Remote Release: REM1 is intended for push-button release where the lock will open for the normal set time. REM2 is intended for use where the lock needs to be released for a longer period. When a switch or relay connected to REM2 is closed, the lock will open for a period of 30 minutes after which the lock will revert to normal operation.

Sensor Mode: Allows two dry contact switches or sensors (door status and latch monitoring) to be connected. Trigger entry will be added to the audit trail.

CL4520

Mortice Lock with Double Cylinder

Euro profile mortice sash lock with deadbolt and latchbolt safety feature. Inside lever and key functions as CL4510. Lockcase key retracts latchbolt for entry without using a code. Key controls deadbolt position. Deadbolt denies access by code, when projected, safety features allow inside lever handle to retract the deadbolt and latchbolt preventing accidental lock in. The key can be used to open doors for management functions such as security and cleaning.

CODE FREE ACCESS

Set via the keypad or via smartphone.

Sensor + Alert: A hybrid mode combining the support for a single dry contact switch or sensor (as per Sensor Mode) and an output. The output can be connected to any compatible device, such as CCTV, with an input that supports the detection of a falling (changing) voltage.

Unlock + Lock Down: Support the connection of two dry contact switches. Connected to REM1, the switch will unlock the lock for the period set by the standard re-lock delay. Connected to REM2, the switch would trigger the Lock Down Mode of the lock where on the Master and Sub-Master Code can be used for entry.

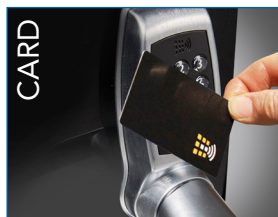

PRODUCT DIMENSIONS

CL4510

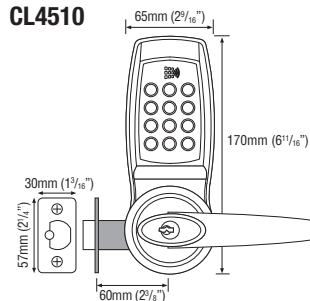

CL4520

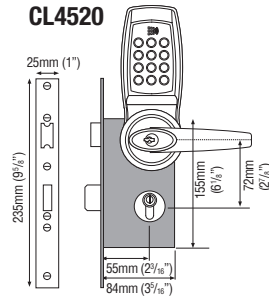

Apple, the Apple logo, and iPhone are trademarks of Apple Inc., registered in the U.S. and other countries. App Store is a service mark of Apple Inc. Android, Google Play and the Google Play logo are trademarks of Google Inc.

*Codelocks electronic locks offer a two year guarantee and will be repaired, serviced or replaced free of charge if they develop a manufacturing fault. Faults caused by misuse, abuse and/or poor fitting are not covered by the guarantees.

Levco Agencies
P: 04 473 3025 | E: sales@levco.co.nz

www.levco.co.nz

CODELOCKS

FEATURES

- Up to 350 Users
- 100 Phone Clients
- 100 Client User Codes
- 150 Client Smart Cards
- 12 button back-lit keypad
- Keyless entry - no lost keys
- NetCode generation technology
- Set up to 10 Code Free access periods
- Suspend and Restore any or all Clients
- Mortice Latch and Mortice Lock available
- Keypad indicates locked / unlocked status
- Tamper time out and low battery warning
- Manage and operate locks via smartphone
- Personal wireless connectivity for management
- Simple upgrade from CL4000 range using same fixings
- Auxiliary Connections enabling four different modes of operation

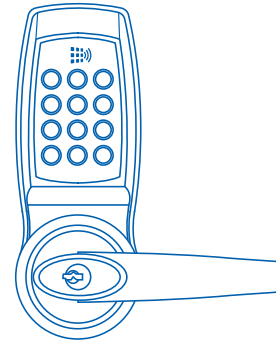

TECHNICAL SPECIFICATIONS

Battery Status	Monitor via App
Batteries	4 x AA Cells
Low Battery Warning	The keypad will flash red on opening to indicate batteries need to be changed
Memory	Stores 350 different Clients
Client User Codes	100
Client Smart Cards	150
Phone Clients	100
Spindle Type	8mm (5/16") spring loaded spindle
Material	Zinc Alloy
Door Thickness	35mm – 60mm (1 3/8" – 2 3/8")
Latch Options	60mm (2 3/8") and 70mm (2 3/4")
Buttons	12 button back-lit keypad
Non Handed	Locks will fit doors hung on the left or right
Fitting Options	Vertical
Finish	Brushed Steel
Keying Alike	Locks can be supplied as keyed alike on request
Key Override	As standard
Codes	4 digit User Code / 6 digit NetCode / 8 digit Master Code
Smartphone App	K3 Connect App
PC Programming	NetCode Function only
NetCode	6 digit NetCode
Audit Trail	Function available
Auxiliary Connections	Two connectors (REM Ports) Four modes of operation: Remote Release, Sensor Mode, Sensor + Alert and Unlock + Lock Down
Storeroom Function	Fitted with storeroom tailpiece as standard Latch can be retracted by key when turned
Classroom Function	Tailpiece supplied to allow (when fitted) lock to be left in code free mode when key is removed

cluk2017v1